

TECHNICAL DATA SHEETS
and
RECOMMENDATIONS

ABER

Manufacturing Hydraulic Excellence since 1972

www.ABER.pt



GEAR PUMPS RECOMMENDATIONS BEFORE START-UP



Manufacturer's Declaration

ABER ensures compliance of its products with the essential health and safety requirements of the harmonized standards EN ISO 12100:2010 and ISO 4413:2010

General information

ABER gear pumps are single fixed displacement pumps. They are available from 12 to 154 cm³/rev. over different range series. They can be assembled directly into the PTO, with the exception of the PTO of two shafts without support.

Features:

- Bidirectional
- Good performance
- Small dimensions
- Light
- Fast to mount
- Low noise
- Low weight
- Changeable direction of rotation (unidirectional version)

Pump selection

To ensure that the PTO will not be overloaded, and to get the correct flow requirements with the speed of the engine chosen, it is important to use a pump with the right capacity. Pump capacity (D), expressed in cm³/rev, can be calculated using the following formula:

$$D = \frac{Q \times 1000}{N \times Z}$$

D-Pump displacement [cm³/rev]
Q-Flow required [l/min]
N-Motor speed
Z-Engine to PTO ratio

In order not to overload the PTO's mechanical units, it is important to calculate the torque and power consumed by the pumps. Torque and power are calculated with the following formula:

$$M = \frac{D \times P_b}{63} \quad P = \frac{D \times N \times Z \times P_b}{600 \times 0,90 \times 1000}$$

M-Torque [Nm]
P_b-Pressure [bar]
P-Power [kW]
N-Motor speed [rpm]
Z-PTO ratio
0,90-Pump efficiency (can change from one pump to another)

ATTENTION

selected.

If the calculated load exceeds the maximum allowed for the PTO, a different combination should be

Hose selection

In order to avoid intense heat generation and cavitation phenomenon that causes noise and pump deterioration, ABER recommends the following speeds and dimensions of the hoses.

Admission line

0,5...1 m/s

Return line

2...3 m/s

Pressure line

P = 0...50 bar - 3,5 m/s
P = 50...100 bar - 3,5...4,5 m/s
P = 50...100 bar - 3,5...4,5 m/s
P = 150...200 bar - 5...5,5 m/s
P = 200...300 bar - 5,5...6 m/s

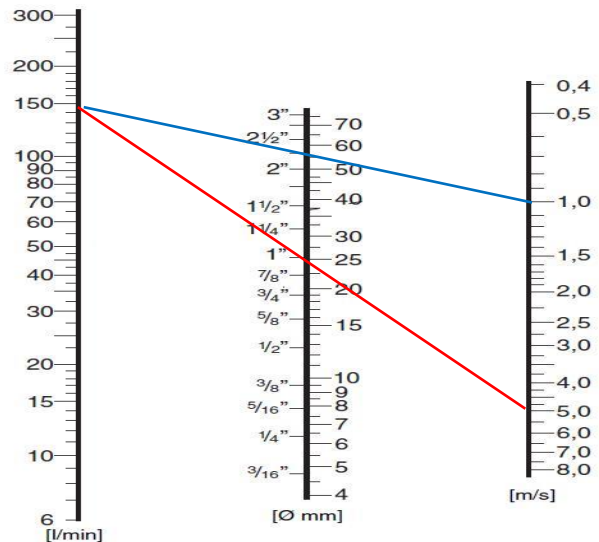

ATTENTION

The recommended speeds and dimensions specified may not be enough when temperatures are too low, the tank is below the level of the pump, the inlet hose is long or there are many valves and fittings in the inlet hosing. In these cases we recommend increasing the diameter of the hoses, keeping the suction hose as short and straight as possible and reducing the pump rotation speed.

ABER is constantly engaged in improving its products and, therefore, reserves itself the right to modify without any further notice the characteristics shown



ABER - Embragens e Comandos Hidráulicos - A. B. LDA

Rua Francisco de Almeida, Nº 30 – Vila Nova da Telha – 4470 MAIA - Portugal

Telephone: +351.22.9438070 Fax: +351.22.9420823 e-mail: aber@aber.pt <http://www.aber.pt>



GEAR PUMPS RECOMMENDATIONS BEFORE START-UP

Direction of rotation

The direction of rotation of the pump must be according to the PTO rotation. ABER can supply bidirectional or unidirectional pumps

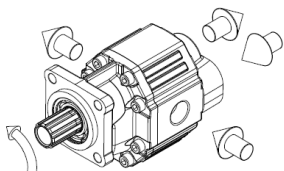

Left Hand (CCW)

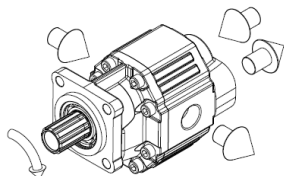

Right hand (CW)

i Rotation sense is defined from drive shaft. Unidirectional gear pumps must be ordered CCW or CW

Changing the rotation

To change the rotation of the unidirectional pump it is necessary to follow the next steps.

(B3 Series: example of how to change the rotation)

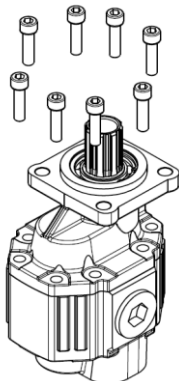

1°- Loosen and remove the top screws and washers

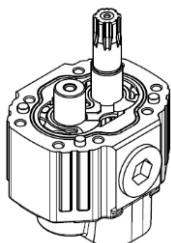

2°- Remove the cover. If the cover is stuck tap around the edge with a rubber mallet to disconnect the cover and the body

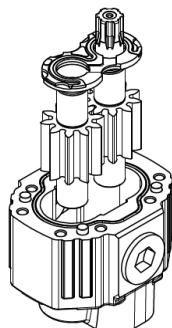

3°- Remove the top plate and the gears. The rear plate should not be removed. Remove first the main shaft to facilitate the removal of the top plate

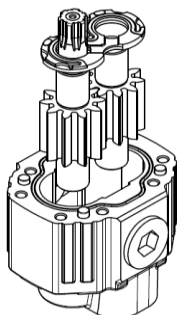

4°- Reassemble the gears in the opposite position and the plate in the same position

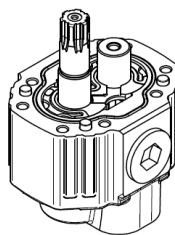

5°- With the use of grease, reapply the oring



6°- Be sure that the plate seal is assembled on the pressure side (P side). Be aware that the seal tips should not be damaged when inserting the plate

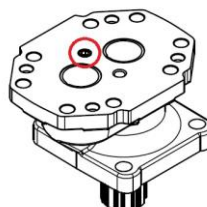

7°- Replace the hex bolt in the cover from one hole to another. Tighten the hex bolt with 20N.m torque

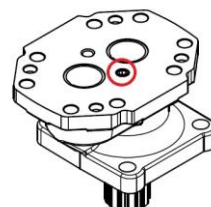

8°- Be aware that hex bolt stays in the pump pressure side (P side)

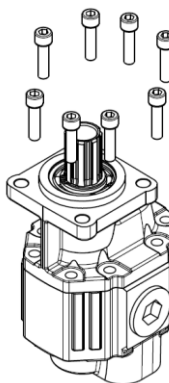

9°- Assemble the pump cover (turned 180° from its original position) and tighten the top screws and washers with the 80 N.m

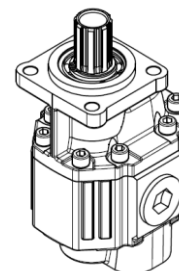

10° - By hand rotate the main shaft to ensure that the pump rotates freely. The pump is now ready for working with the original rotation reversed

Torque tightness plugs

3/4" BSP	60 N.m
1" BSP	75 N.m
1 1/4" BSP	115 N.m

ABER is constantly engaged in improving its products and, therefore, reserves itself the right to modify without any further notice the characteristics shown



ABER - Embragens e Comandos Hidráulicos - A. B. LDA

Rua Francisco de Almeida, Nº 30 – Vila Nova da Telha – 4470 MAIA - Portugal

Telephone: +351.22.9438070 Fax: +351.22.9420823 e-mail: aber@aber.pt <http://www.aber.pt>



GEAR PUMPS RECOMMENDATIONS BEFORE START-UP

Installation instructions

1. Check PTO direction of rotation and fit the pump according to PTO sense of rotation. Make sure that the assembly does not generate axial or radial load on the pump main shaft
2. Grease spline shaft with solid lubricant before installation when the PTO contains an output shaft seal. Connect the pump to the PTO (apply 80Nm torque in the tightening nuts). Elevated efforts or shocks are not recommended during the installation. The pump must be connected without making use of any type of tool that forces its assembly.

ATTENTION During the installation always leave the inlet port in a higher or equal level than outlet port. This increases the pump's life.

3. Remove all protection covers from the threaded holes (inlet/outlet). Apply the inlet and outlet fittings into the pump (ask for the tightening information's from the fittings manufacturer). Connect the outlet and the inlet pipes to the accessories (always respect recommended hoses dimensions and thread dimensions). Be sure that all connections are robust and well-sealed.

Axial and radial load

Gear pumps that are subjected to axial and radial loads (such as driving gears and couplings) must be fitted with double tapered roller bearings to support the loads (ABER reinforced gear pump versions)
In driving gear application and couplings use circlips and/ or washers with one M10 screw and locking fluid (70Nm).

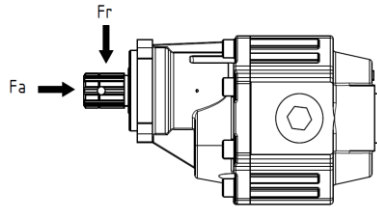

Pressure definition

Maximum allowed pressure can change according to the time that the pump is under load. Continuous, intermittent and pike pressures can occur. For their maximum values and times consult technical sheet and, or contact ABER.

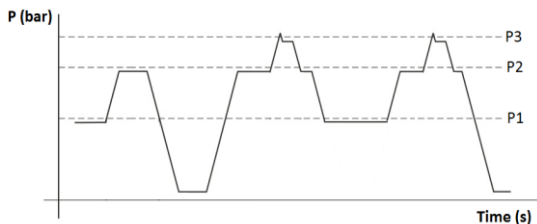

- P1 – Continuous pressure
- P2 – Intermittent pressure
- P3 – Peak pressure

ABER is constantly engaged in improving its products and, therefore, reserves itself the right to modify without any further notice the characteristics shown

Fluids

For the gear pump range, ABER recommends the use of high quality mineral oil type ISO HM or DIN 51524-2 HLP, with viscosities from 20 to 40mm²/s (cSt) at working temperature. The recommended oil viscosity limits stay between minimum 10mm²/s (cSt) and maximum 100mm²/s (cSt). The maximum started viscosity at start up is 750 mm²/s (cSt). It is possible to use other oils with the same characteristics, but only after consulting and getting authorization from ABER. The designation 32, 46, 68, etc. denotes the viscosity at 40°C of the oil. When choosing the oil it is necessary to be aware of the low viscosity with the increase of the temperature, therefore, we recommend that when you want to work above that temperature, you should choose an oil with more viscosity (thicker) in order to compensate the reduction of viscosity when the temperature increases. The oil temperature must be maintained between -25°C and 80°C. We advise you to use an oil cooler when you verify that the system's temperature is higher than these values. The oil must be replaced after 1000 working hours or at least once a year, change filters elements as well.

Leakage safety system

ABER gear pumps do not need to use an exterior drain line because they are drained from the inside. These pumps have two shaft seals to guarantee protection avoid the oil exchange between the hydraulic circuit and the gear box. In case of failure, a safety system between the shaft seals of the pump allows the oil to escape, but doesn't allow the entry of contamination into the pump.

ATTENTION If any oil leaks out from the pump, stop the system immediately to determine the cause of the leak and correct the problem source.

Filtration

The filtration is extremely important and may influence or even determine the durability of the equipment. ABER recommends the use of a return filter and an air filter with an absolute filtration degree of 10µm if the pressure system is higher than 200 bar and an absolute filtration degree of 25 µm if the pressure system is lower than 200 bar, as according to the ISO 4406 class 18/13. The first filter to be applied into the system must be replaced as soon as it reaches the 50 working hours; after the first replacement, it must be replaced along with the oil or when uncommon pressures are verified in the return.

ATTENTION Be sure that the whole system is perfectly cleaned before filling it with oil. Never mix water or other liquids, different oil qualities, viscosities or brands with the oil in the system. Make sure that there was no gearbox contamination.

CTI Gear pumps recommendations before start-up 1603-1



ABER - Embragens e Comandos Hidráulicos - A. B. LDA

Rua Francisco de Almeida, Nº 30 – Vila Nova da Telha – 4470 MAIA - Portugal

Telephone: +351.22.9438070 Fax: +351.22.9420823 e-mail: aber@aber.pt <http://www.aber.pt>



GEAR PUMPS RECOMMENDATIONS BEFORE START-UP

Faults; cause and remedies

Faults	Cause	Remedies
No oil flow	<ol style="list-style-type: none"> 1. Empty tank 2. Closed valve in inlet hose 3. Air in inlet hose 4. Wrong sense of rotation 5. Reversed hoses 6. PTO not engaged 7. Pump damaged 	<ol style="list-style-type: none"> 1. Fill tank with recommended fluid 2. Open valve 3. Put tank above the pump level 4. Change pump rotation sense 5. Change inlet and pressure hoses 6. See "PTO Troubleshooting" 7. Replace pump
Equipment works with irregular movements	<ol style="list-style-type: none"> 1. Air in housing 2. Air leakage in inlet hose 3. Low oil level 4. Pump damaged 	<ol style="list-style-type: none"> 1. Fill housing with recommended fluid 2. Repair air leakage 3. Fill tank with recommended fluid 4. Replace pump
Pump is noisy	<ol style="list-style-type: none"> 1. Cavitation 2. Very thick oil 3. Air in inlet hose 4. Pump damaged 	<ol style="list-style-type: none"> 1. Replace inlet hose for other with a larger diameter 1. Remove inlet restrictions 1. Check for clogged tank breather or clogged admission filter 2. Replace for an recommended fluid 3. Put tank above the pump level, check air pressure in the tank 4. Replace pump
Oil is too hot	<ol style="list-style-type: none"> 1. Low oil level 2. Small tank 3. Dirty oil 4. Relief valve improperly set 5. Relief valve stuck in open position 6. Very thick oil 7. Too much flow 8. Undersized system 	<ol style="list-style-type: none"> 1. Fill tank with recommended fluid 2. Replace for a bigger tank 3. Replace oil and filter 4. Adjust for equipment specifications or replace if necessary 5. Clean and re-set for equipment specifications 6. Replace for an recommended fluid 7. Reduce speed or replace for a smaller displacement pump 8. Review application system
Equipment works very slow compared with the usual	<ol style="list-style-type: none"> 1. Relief valve improperly set 2. Relief valve stuck in open position 3. Pump damaged 	<ol style="list-style-type: none"> 1. Adjust for equipment specifications or replace if necessary 2. Clean and re-set for equipment specifications 3. Replace pump
Oil leakage	<ol style="list-style-type: none"> 1. From inlet/outlet lines 2. From drain hole 3. From shaft seal 4. From body sections 	<ol style="list-style-type: none"> 1. Tighten fittings and hoses, or replace if necessary 2. Stop the system immediately to determine the cause of the leak and correct the problem source 3. Replace shaft seal 4. Tighten bolts for specified torque, or replace damaged oring or body



When the pump is working never touch or pull hoses or intermediate shaft when applied. When intermediate shaft is applied take into account that parts can be ejected.

The application of the pumps must follow all the instructions hereby mentioned in order to assure the safety of all personal working with the equipment including its surroundings, assure a long life to the product and preserve the warranty of the brand. All applications that do not follow the hereby instruction are solely the users responsibility. If there should happen any malfunctioning, it is strictly forbidden the disassembly of the product except if it is being made by a qualified technician of the brand or if there is a special authorization to do so. If this specification should not be followed, all warranties might be lost.

ABER is constantly engaged in improving its products and, therefore, reserves itself the right to modify without any further notice the characteristics shown



ABER - Embraagens e Comandos Hidráulicos - A. B. LDA

Rua Francisco de Almeida, Nº 30 – Vila Nova da Telha – 4470 MAIA - Portugal

Telephone: +351.22.9438070 Fax: +351.22.9420823 e-mail: aber@aber.pt <http://www.aber.pt>



Main Dimensions

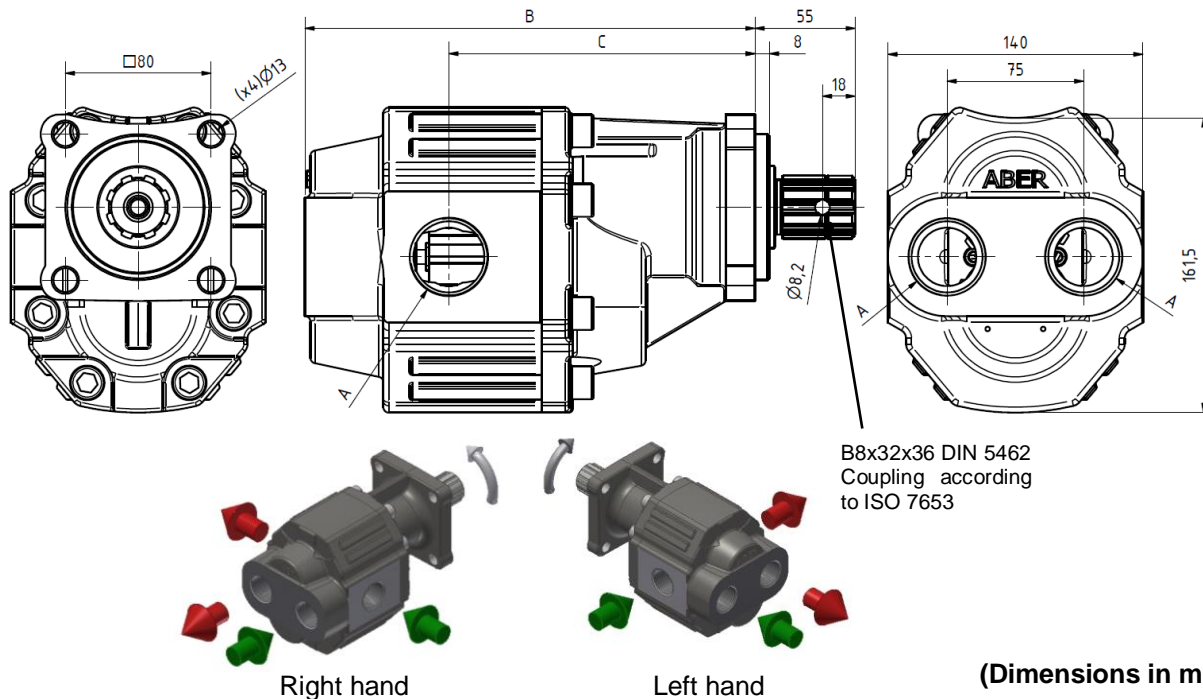

(Dimensions in mm)

Main Data

Pumps B354GTR		64	74	84	94	104	114	124	134	154
Displacement	cm ³ /rev.	64.5	74.7	83.8	94.0	104.2	114.5	124.7	133.7	154.2
Max. rotation speed	rpm	2000	2000	1800	1800	1800	1800	1600	1500	1500
Min. rotation speed	rpm	300	300	300	300	300	300	300	300	300
Max. continuous pressure	bar	300	300	270	260	250	250	240	230	185
Max. intermittent pressure (max. 20s)	bar	320	320	290	280	270	270	260	250	205
Max. peak pressure (max. 6s)	bar	335	335	305	295	285	285	275	265	220
Weight	kg	18	18	19	19	20	20	21	22	23
Sense of Rotation		Bidirectional								
A - Inlet / Outlet (DIN ISO 228)	G (BSP)	1"			1"1/4					
B	mm	221	225	229	234	238	243	247	251	260
C	mm	145	149	152	156	160	164	168	171	180

How to order:

Example: Pump 84 cm³/rev, operating pressure up to 270 bar; peak pressure 305 bar, ref.B354GTR, → B354GTR84

Note: Usually, used in frontal cylinders

Fluids	mineral oils type ISO HM or DIN 51524-2 HLP
Operating viscosity range	10 to 100 cSt (mm ² /s) at working temperature
Máx operating limits viscosity	750 cSt
Oil temperature range	-25°C to 80°C
Filtration	>200bar = 10µm <200bar = 25 µm
In the application of any of these pumps; the use of these data does not exempt the reading of the instruction "Gear pumps recommendations before start-up".	

ABER is constantly engaged in improving its products and, therefore, reserves itself the right to modify without any further notice the characteristics shown



ABER - Embraigens e Comandos Hidráulicos - A. B. LDA

Rua Francisco de Almeida, N^o 30 – Vila Nova da Telha – 4470 MAIA - Portugal

Telephone: +351.22.9438070 Fax: +351.22.9420823 e-mail: aber@aber.pt <http://www.aber.pt>

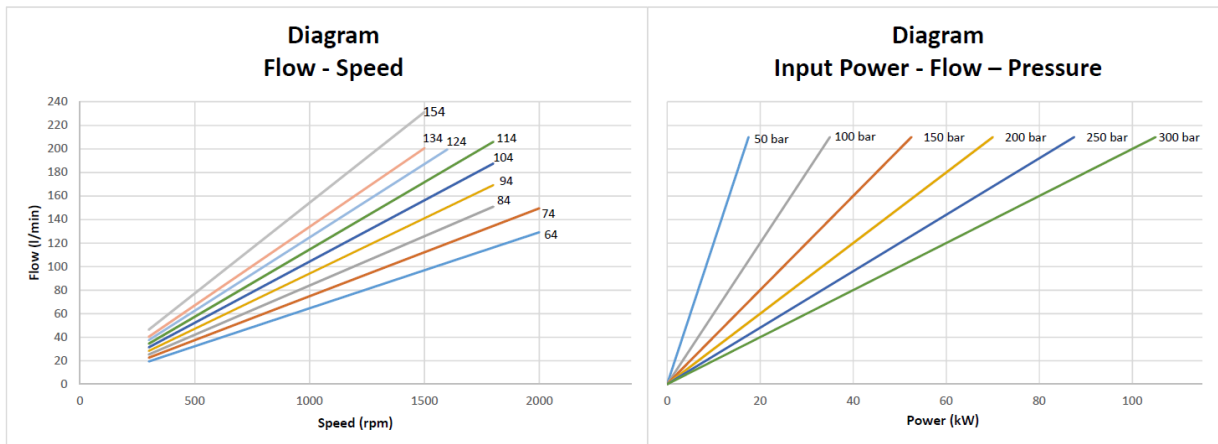

Hose dimensions

Inlet Hose	
Flow (l/min)	Internal pipe diameter (inch)
30-40	1"1/4
50-60	1"1/2
70-90	1"3/4
100-120	2"
130-150	2"1/4
160-190	2"1/2
200-230	2"3/4

Outlet Hose					
Flow (l/min)	Internal pipe diameter (inch)				
	30	1/2"	1/2"	1/2"	1/2"
40	5/8"	1/2"	1/2"	1/2"	
50	5/8"	5/8"	5/8"	1/2"	
60	3/4"	5/8"	5/8"	5/8"	
70	1"	3/4"	3/4"	5/8"	
80	1"	3/4"	3/4"	3/4"	
90	1"	1"	1"	3/4"	
100	1"	1"	1"	1"	
110	1"	1"	1"	1"	
120	1"	1"	1"	1"	
130	1"	1"	1"	1"	
140	1"1/4	1"	1"	1"	
150	1"1/4	1"	1"	1"	
160	1"1/4	1"1/4	1"	1"	
170	1"1/4	1"1/4	1"	1"	
180	1"1/4	1"1/4	1"1/4	1"	
190	1"1/4	1"1/4	1"1/4	1"	
200	1"1/2	1"1/4	1"1/4	1"1/4	
210	1"1/2	1"1/4	1"1/4	1"1/4	
220	1"1/2	1"1/4	1"1/4	1"1/4	
		50-100	100-150	150-200	200-300
P (bar)					

Important notes:

- Other axis available, please consult "Axel options".

ABER is constantly engaged in improving its products and, therefore, reserves itself the right to modify without any further notice the characteristics shown



ABER - Embraigens e Comandos Hidráulicos - A. B. LDA

Rua Francisco de Almeida, N° 30 – Vila Nova da Telha – 4470 MAIA - Portugal

Telephone: +351.22.9438070 Fax: +351.22.9420823 e-mail: aber@aber.pt <http://www.aber.pt>



Main Dimensions

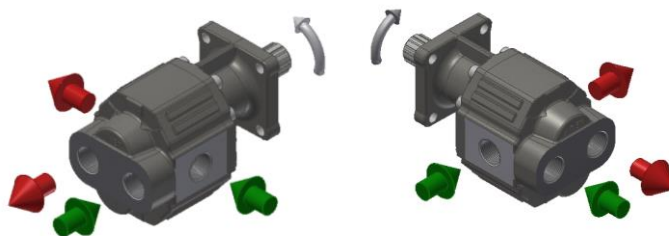
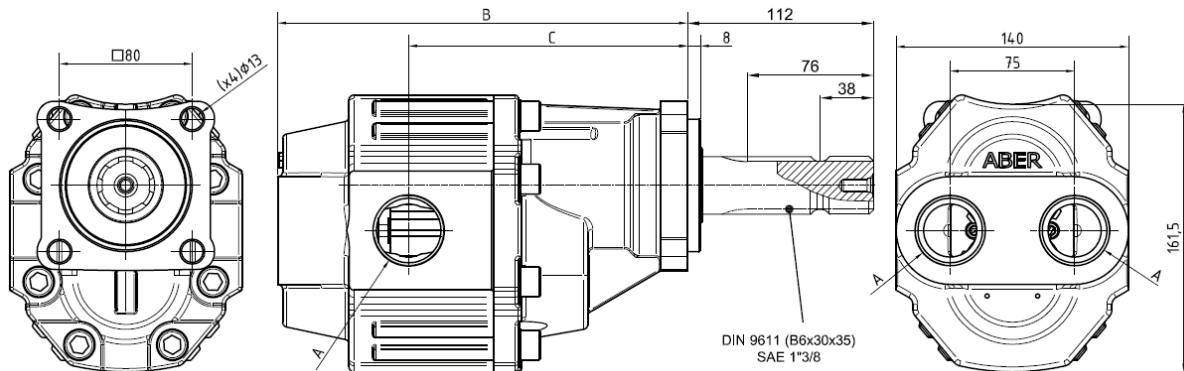

Right hand

Left hand

(Dimensions in mm)

Main Data

Pumps B354GTR_DA		64	74	84	94	104	114	124	134	154
Displacement	cm ³ /rev.	64.5	74.7	83.8	94.0	104.2	114.5	124.7	133.7	154.2
Max. rotation speed	rpm	2000	2000	1800	1800	1800	1800	1600	1500	1500
Min. rotation speed	rpm	300	300	300	300	300	300	300	300	300
Max. continuous pressure	bar	300	300	270	260	250	250	240	230	185
Max. intermittent pressure (max. 20s)	bar	320	320	290	280	270	270	260	250	205
Max. peak pressure (max. 6s)	bar	335	335	305	295	285	285	275	265	220
Weight	kg	18	18	19	19	20	20	21	22	23
Sense of Rotation		Bidirectional								
A - Inlet / Outlet (DIN ISO 228)	G (BSP)	1"			1 1/4"					
B	mm	221	225	229	234	238	243	247	251	260
C	mm	145	149	152	156	160	164	168	171	180

How to order:

Example: Pump 84 cm³/rev, operating pressure up to 270 bar; peak pressure 305 bar, ref.B354GTR_DA, → B354GTR84DA

Note: Usually, used in frontal cylinders

Fluids	mineral oils type ISO HM or DIN 51524-2 HLP
Operating viscosity range	10 to 100 cSt (mm ² /s) at working temperature
Máx operating limits viscosity	750 cSt
Oil temperature range	-25°C to 80°C
Filtration	>200bar = 10µm <200bar = 25 µm
In the application of any of these pumps; the use of these data does not exempt the reading of the instruction "Gear pumps recommendations before start-up".	

ABER is constantly engaged in improving its products and, therefore, reserves itself the right to modify without any further notice the characteristics shown



ABER - Embraiaçens e Comandos Hidráulicos - A. B. LDA

Rua Francisco de Almeida, N^o 30 – Vila Nova da Telha – 4470 MAIA - Portugal

Telephone: +351.22.9438070 Fax: +351.22.9420823 e-mail: aber@aber.pt <http://www.aber.pt>

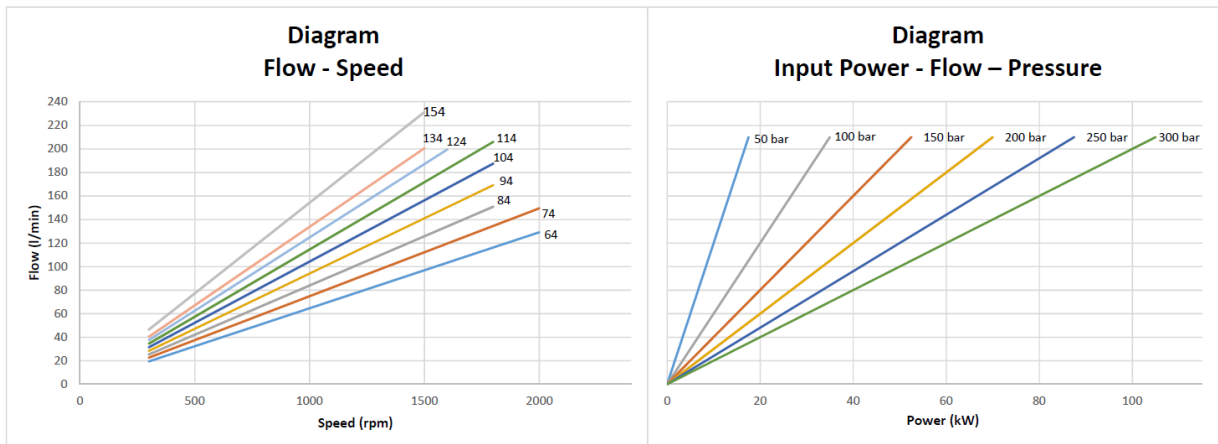

Hose dimensions

Inlet Hose	
Flow (l/min)	Internal pipe diameter (inch)
30-40	1"1/4
50-60	1"1/2
70-90	1"3/4
100-120	2"
130-150	2"1/4
160-190	2"1/2
200-230	2"3/4

Outlet Hose				
Flow (l/min)	Internal pipe diameter (inch)			
	30	1/2"	1/2"	1/2"
40	5/8"	1/2"	1/2"	1/2"
50	5/8"	5/8"	5/8"	1/2"
60	3/4"	5/8"	5/8"	5/8"
70	1"	3/4"	3/4"	5/8"
80	1"	3/4"	3/4"	3/4"
90	1"	1"	1"	3/4"
100	1"	1"	1"	1"
110	1"	1"	1"	1"
120	1"	1"	1"	1"
130	1"	1"	1"	1"
140	1"1/4	1"	1"	1"
150	1"1/4	1"	1"	1"
160	1"1/4	1"1/4	1"	1"
170	1"1/4	1"1/4	1"	1"
180	1"1/4	1"1/4	1"1/4	1"
190	1"1/4	1"1/4	1"1/4	1"
200	1"1/2	1"1/4	1"1/4	1"1/4
210	1"1/2	1"1/4	1"1/4	1"1/4
220	1"1/2	1"1/4	1"1/4	1"1/4
	50-100	100-150	150-200	200-300
	P (bar)			

Important notes:

- Other axis available, please consult "Axel options".

ABER is constantly engaged in improving its products and, therefore, reserves itself the right to modify without any further notice the characteristics shown



ABER - Embraigens e Comandos Hidráulicos - A. B. LDA

Rua Francisco de Almeida, N° 30 – Vila Nova da Telha – 4470 MAIA - Portugal

Telephone: +351.22.9438070 Fax: +351.22.9420823 e-mail: aber@aber.pt <http://www.aber.pt>



OIL-HYDRAULIC GEAR PUMP

Ref.
B354GTUR

Main Dimensions

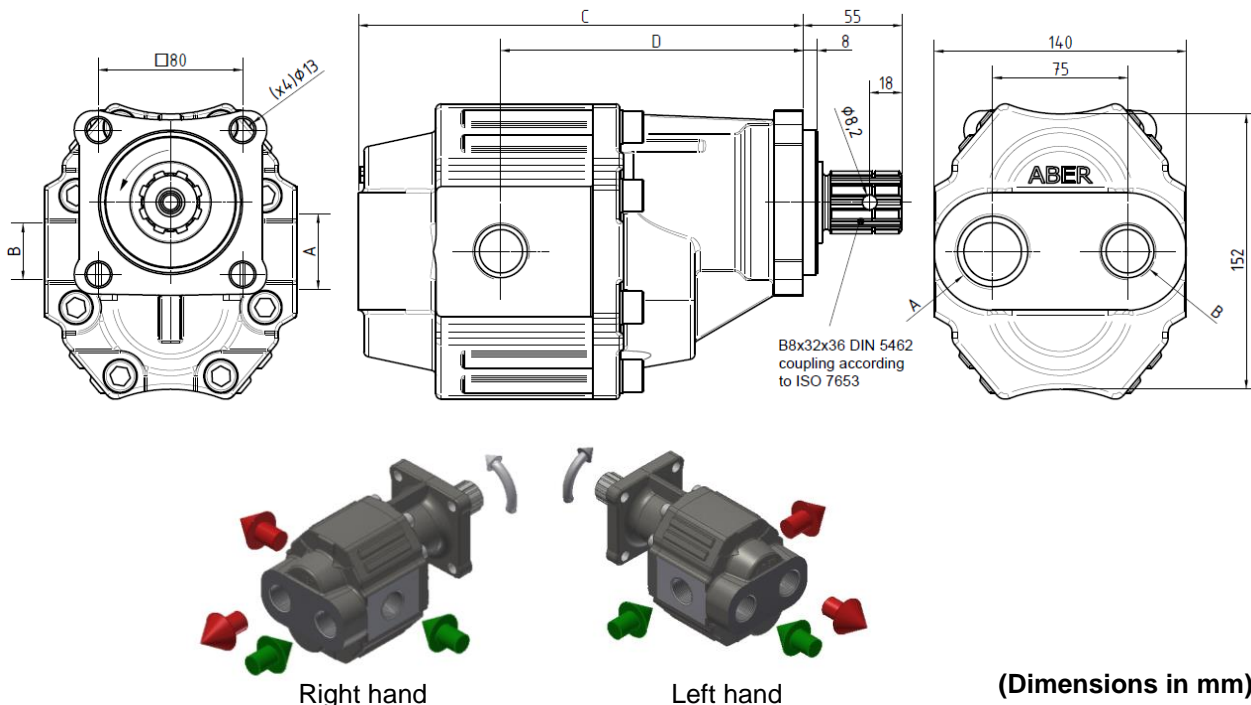

Main Data

Pumps B354GTUR		64	74	84	94	104	114	124	134	154
Displacement	cm ³ /rev.	64.5	74.7	83.8	94.0	104.2	114.5	124.7	133.7	154.2
Max. rotation speed	rpm	2000	2000	1800	1800	1800	1800	1600	1500	1500
Min. rotation speed	rpm	300	300	300	300	300	300	300	300	300
Max. continuous pressure	bar	300	300	270	260	250	250	240	230	185
Max. intermittent pressure (max. 20s)	bar	320	320	290	280	270	270	260	250	205
Max. peak pressure (max. 6s)	bar	335	335	305	295	285	285	275	265	220
Weight	kg	18	18	19	19	20	20	21	22	23
Sense of Rotation		Unidirectional (Left [L] or Right [R])								
A - Inlet (DIN ISO 228)	G (BSP)	1"			1 1/4"					
B - Outlet (DIN ISO 228)	G (BSP)	3/4"			1"					
C	mm	221	225	229	234	238	243	247	251	260
D	mm	145	149	152	156	160	164	168	171	180

How to order:

Example: Pump 84 cm³/rev, operating pressure up to 270 bar; peak pressure 305 bar, ref.B354GTUR, rotation left → B354GTUR84L

Fluids	mineral oils type ISO HM or DIN 51524-2 HLP
Operating viscosity range	10 to 100 cSt (mm ² /s) at working temperature
Máx operating limits viscosity	750 cSt
Oil temperature range	-25°C to 80°C
Filtration	>200bar = 10µm <200bar = 25 µm
In the application of any of these pumps; the use of these data does not exempt the reading of the instruction "Gear pumps recommendations before start-up".	

ABER is constantly engaged in improving its products and, therefore, reserves itself the right to modify without any further notice the characteristics shown



ABER - Embraagens e Comandos Hidráulicos - A. B. LDA

Rua Francisco de Almeida, Nº 30 – Vila Nova da Telha – 4470 MAIA - Portugal

Telephone: +351.22.9438070 Fax: +351.22.9420823 e-mail: aber@aber.pt <http://www.aber.pt>



OIL-HYDRAULIC GEAR PUMP

Ref.
B354GTUR

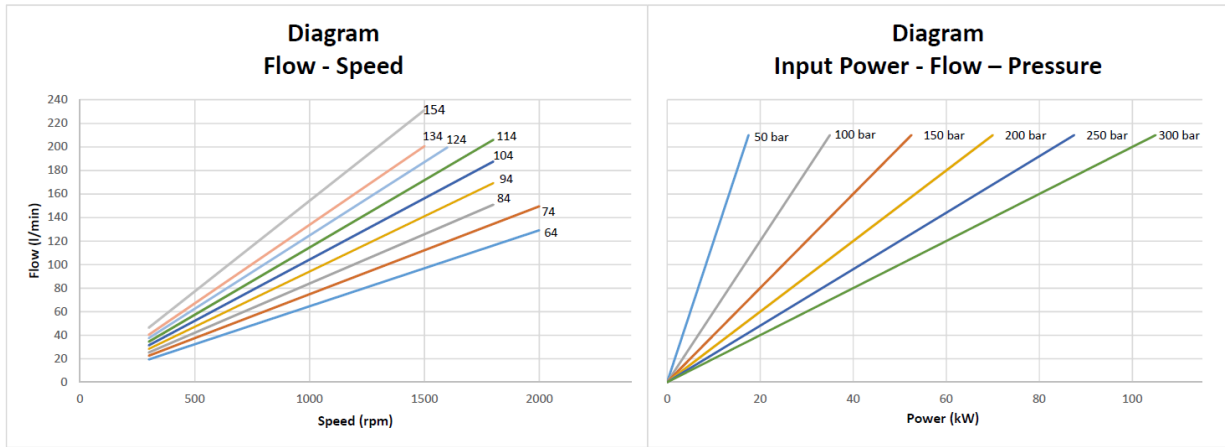

Hose dimensions

Inlet Hose	
Flow (l/min)	Internal pipe diameter (inch)
30-40	1"1/4
50-60	1"1/2
70-90	1"3/4
100-120	2"
130-150	2"1/4
160-190	2"1/2
200-230	2"3/4

Outlet Hose				
Flow (l/min)	Internal pipe diameter (inch)			
	1/2"	1/2"	1/2"	1/2"
30	1/2"	1/2"	1/2"	1/2"
40	5/8"	1/2"	1/2"	1/2"
50	5/8"	5/8"	5/8"	1/2"
60	3/4"	5/8"	5/8"	5/8"
70	1"	3/4"	3/4"	5/8"
80	1"	3/4"	3/4"	3/4"
90	1"	1"	1"	3/4"
100	1"	1"	1"	1"
110	1"	1"	1"	1"
120	1"	1"	1"	1"
130	1"	1"	1"	1"
140	1"1/4	1"	1"	1"
150	1"1/4	1"	1"	1"
160	1"1/4	1"1/4	1"	1"
170	1"1/4	1"1/4	1"	1"
180	1"1/4	1"1/4	1"1/4	1"
190	1"1/4	1"1/4	1"1/4	1"
200	1"1/2	1"1/4	1"1/4	1"1/4
210	1"1/2	1"1/4	1"1/4	1"1/4
220	1"1/2	1"1/4	1"1/4	1"1/4
50-100		100-150	150-200	200-300
P (bar)				

Important notes:

- Other axis available, please consult "Axel options".

ABER is constantly engaged in improving its products and, therefore, reserves itself the right to modify without any further notice the characteristics shown



ABER - Embraigens e Comandos Hidráulicos - A. B. LDA

Rua Francisco de Almeida, Nº 30 – Vila Nova da Telha – 4470 MAIA - Portugal

Telephone: +351.22.9438070 Fax: +351.22.9420823 e-mail: aber@aber.pt <http://www.aber.pt>